



Series X57X Quick-Release Universal Zero-Insertion-Force DIP Test Socket

FEATURES

- Universal Test Socket accepts devices on 0.300 to 0.600 [7.62 to 15.24] centers
- All pin count sockets go into PCB with either 0.300 or 0.600 [7.62 to 15.24] centers
- Swing quick-release handle down to open contacts and insert device. Release and handle automatically returns as contacts close onto device leads
- Socket handle can be mounted on either the right or left side
- Sockets can be soldered into PCBs or plugged into any socket

GENERAL SPECIFICATIONS

- STANDARD SOCKET BODY: (for -10, -10TL, -11, -16 sockets) black UL 94V-0 glass-filled Polyphenylene Sulfide (PPS)
- HIGH-TEMPERATURE SOCKET BODY: (for -18 socket) natural color Polyetheretherketone (PEEK)
- HANDLE: Stainless Steel
- HANDLE KNOB: Brass 360, 1/2-hard (no knob on loop handle)
- CONTACT MATERIAL: (for -10, -10TL, -11) BeCu 172 per QQ-C-553; (for -16) Spinodal; (for -18) BeNi 360, 1/2-hard
- ALL BECU CONTACTS: 50μ [1.27μ] min. Ni under plate per QQ-N-290, over plated with either: -10 200μ [5.08μ] min. matte Sn per ASTM B545-97; or -10TL 200μ [5.08μ] min. 90/10 Sn/Pb per MIL-T-10727-11 10μ [0.25μ] min. Au per MIL-G-45204
- SPINODAL CONTACT PLATING: (for -16) 50μ [1.27μ] min. NiB
- HIGH-TEMPERATURE BeNi CONTACT PLATING: (for -18) 50μ [1.27μ] NiB
- CONTACT CURRENT RATING: 1 amp
- INSULATION RESISTANCE: 1000 mΩ min.
- DIELECTRIC WITHSTANDING VOLTAGE: 1000 VAC
- LIFE CYCLE: 25,000 to 50,000 cycles
- OPERATING TEMPERATURE: min. -67°F [-55°C]; max. 221°F [105°C] for Sn plating, 302°F [150°C] for Au plating, 392°F [200°C] for NiB plating, 482°F [250°C] for high-temperature socket
- RETENTION FORCE (closed): 55 grams/pin based on a 0.020 [0.51] dia. test lead
- ACCEPTS LEADS: 0.015-0.035 [0.38-0.89] wide, 0.110-0.280 [2.79-7.11] long

MOUNTING CONSIDERATIONS

- See socket footprint below

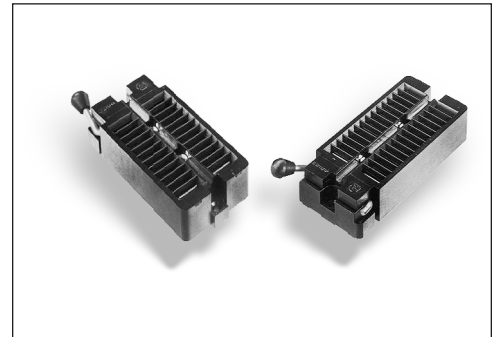

CUSTOMIZATION: In addition to the standard products shown on this page, Aries specializes in custom design and production. Special materials, platings, sizes, and configurations can be furnished, depending on the quantity. **NOTE:** Aries reserves the right to change product general specifications without notice.

ORDERING INFORMATION

XX-X57X-1 X

Pins

24, 28, 32, 36,
40, 42, 44, 48

Row-to-Row Spacing (btm)

3 = 0.300 [7.62]
6 = 0.600 [15.24] (std)

Plating

0 = Sn over Ni
OTL = Sn/Pb over Ni
1 = Au over Ni
6 = NiB (Spinodal)
8 = Hi-temp Socket*

Solder Pin Tail

45° Handle Options

0 = Long Handle, right side
1 = Long Handle, left side
2 = Short Handle, right side
3 = Short Handle, left side
4 = Loop Handle, right side
5 = Loop Handle, left side

* **NOTE: only Loop Handle available w/hi-temp. socket**

Handle	Dim "H1"	Dim. "H2"	Dim "H3"
Long w/ Knob	0.568 [14.43]	0.300 [7.62]	0.471 [11.96]
Short w/ Knob	0.317 [8.05]	0.400 [10.16]	0.252 [6.40]
Loop (no Knob)	0.270 [6.86]	0.193 [4.90]	0.405 [10.29]



Bristol, PA 19007-6810 USA
 TEL (215) 781-9956 • FAX (215) 781-9845
 WWW.ARIESELEC.COM • INFO@ARIESELEC.COM





Series X57X Quick-Release Universal Zero-Insertion-Force DIP Test Socket

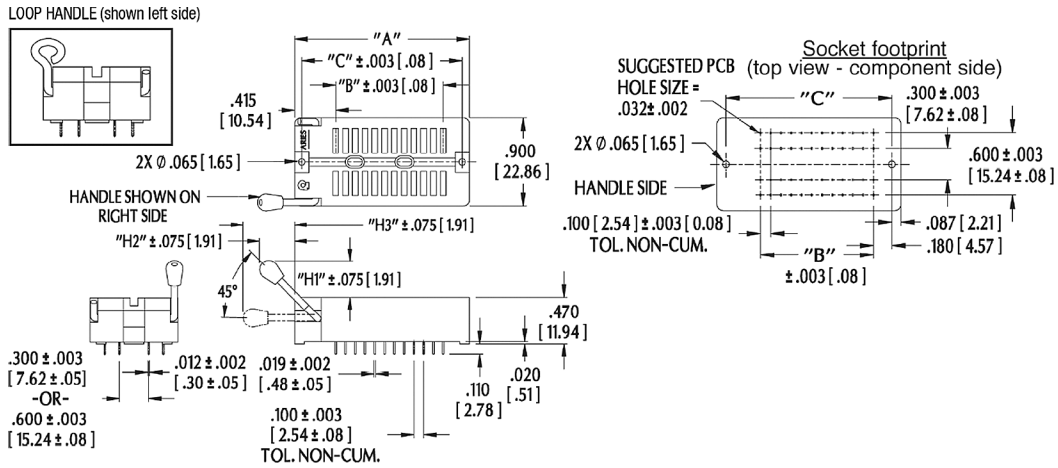

ALL DIMENSIONS: INCHES [MILLIMETERS]

ALL TOLERANCES: ±0.005 [0.13] UNLESS OTHERWISE SPECIFIED

"A" = (NO. OF PINS PER ROW x 0.100 [2.54]) + 0.590 [14.99]

"B" = (NO. OF PINS PER ROW - 1) x 0.100 [2.54]

"C" = (NO. OF PINS PER ROW x 0.100 [2.54]) + 0.415 [10.54]

SOCKET FITS ARIES TEST SOCKET RECEPTACLE XX-6556-XX OR SIMILAR COMPETITOR'S MODELS.

CONSULT [DATA SHEET 10003](#)

CONSULT FACTORY FOR OTHER SIZES AND CONFIGURATIONS



Bristol, PA 19007-6810 USA
 TEL (215) 781-9956 • FAX (215) 781-9845
WWW.ARIESELEC.COM • INFO@ARIESELEC.COM



PRINTOUTS OF THIS DOCUMENT MAY BE OUT OF DATE AND SHOULD BE CONSIDERED UNCONTROLLED

10019
 2 of 2
 Rev. AB