



# 44-Pin 0.8mm QFP-to-44-Pin PLCC Adapter

## FEATURES

- A cost-effective means of upgrading to QFP without changing your PCB layout.

## SPECIFICATIONS

- Board Material: 0.062 thick FR-4 with 1-oz. Cu traces, both sides
- Pins: Brass 360 1/2-hard per UNS C36000, ASTM B16/B16M
- Pin Plating: 200µ" [5.08µm] Sn/Pb 93/7 per ASTM B579-73 over 100µ" [2.54µm] Ni per SAE-AMS-QQ-N-290
- Operating Temperature: 221°F [105°C]

## MOUNTING CONSIDERATIONS

- Standard PLCC SMT Pads

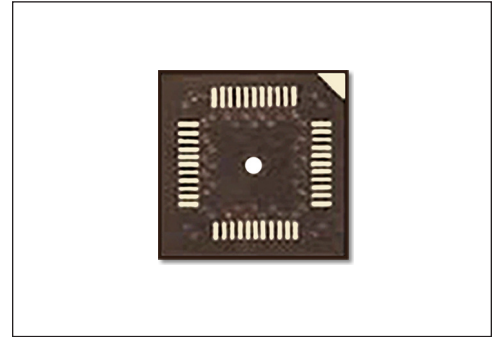

**CUSTOMIZATION:** In addition to the standard products shown on this page, Aries specializes in custom design and production. Special materials, platings, sizes, and configurations can be furnished, depending on quantity. **NOTE:** Aries reserves the right to change product specifications without notice.

ALL DIMENSIONS: INCHES [MILLIMETERS]

All tolerances ±0.005 [0.13] unless otherwise specified

## ORDERING INFORMATION

P/N 44-305263-20

P/N 44-305263-20-P for Panelized Form Version

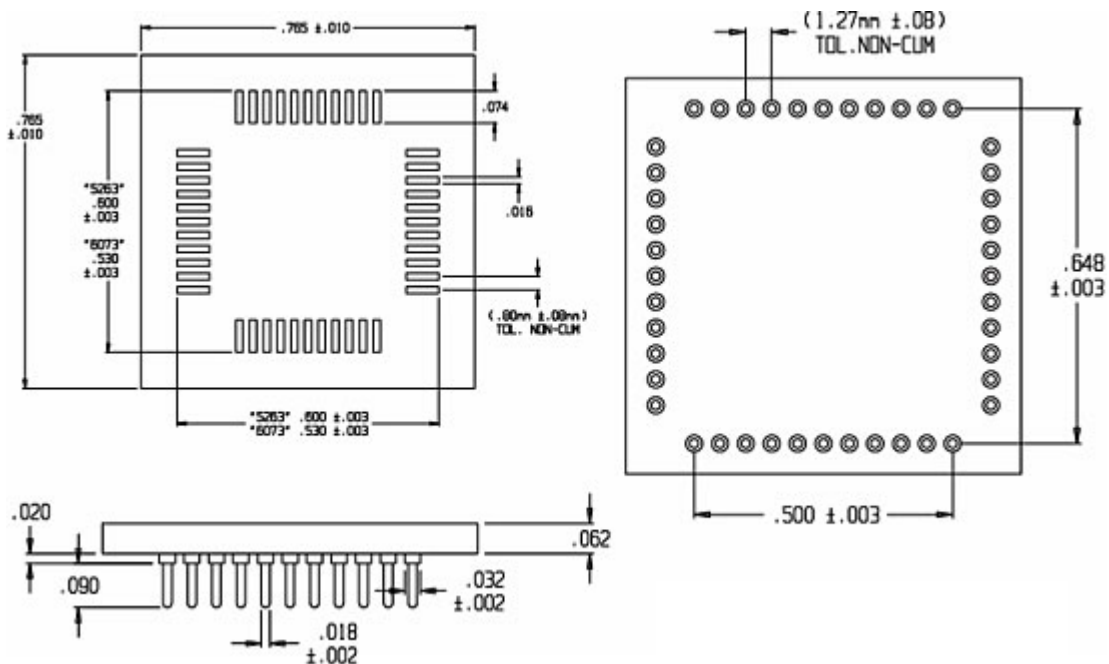

Bristol, PA 19007-6810 USA  
 TEL (215) 781-9956 • FAX (215) 781-9845  
 WWW.ARIESELEC.COM • INFO@ARIESELEC.COM

