



MACHINED HIGH FREQUENCY CENTER PROBE TEST SOCKET FOR BGA, CSP, & MLF PACKAGES

FEATURES:

- Solderless spring probes pressure mount to the test board and device solderball or pad.
- Only .077" (1.95mm) signal path.
- Very low inductance and capacitance.
- Small footprint allows maximum use of test board area.
- Chip guides allow accurate device location.
- Spring loaded contacts provide high cycle life.
- Socket locating posts provide accurate socket location to board.
- Bottom contact allows for via in center of PCB pad.
- Available in pitch sizes from 0.40mm and above.

SPECIFICATIONS:

- Socket body material is Torlon PAI.
- Hardware in stainless steel.
- Beryllium Copper spring loaded contacts w/ Gold Plating.
- Contact Resistance: <40 milliohm.
- Accepts solder ball sizes from .15mm-.93mm.
- 4-point/edge male contacts provide accurate mating.
- Estimated contact life 500,000 cycles.
- Contact force = 16g per contact on 0.40mm pitch.
= 25g per contact on 0.50mm - 0.75mm & 0.80mm or larger
- Probe Self Inductance: .51nH (Large Probe), .59nH (Small Probe).
- Insertion Loss: 1dB to 10.1GHz (larger probe@0.80mm pitch)
1dB to 18.7GHz (smaller probe@0.50mm pitch)

MOUNTING CONSIDERATIONS:

- Suggested locating pin hole size=.063"(1.6mm) 2 places.
- Suggested mounting hole size=.120"(3.05mm) 4 places for #4-40 screws.
- Test board pad diameter:
= .025" (0.635mm) (large probe = 0.80mm pitch or larger)
= .015" (0.381mm) (small probe = 0.50mm - 0.75mm pitch)
= .012" (0.300mm) (small probe = 0.40mm pitch)

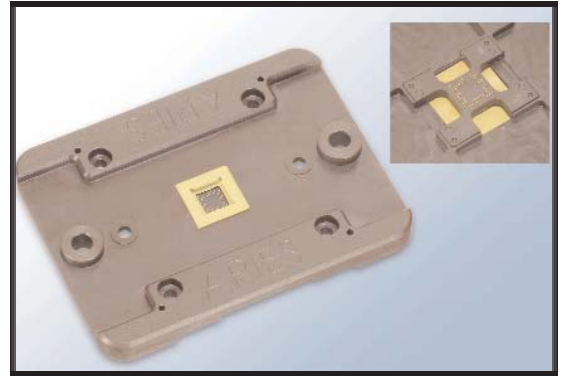

Note: Aries specializes in custom design and production. In addition to the standard products shown on this page, special materials, platings, sizes, and configurations can be furnished, depending on quantities. Aries reserves the right to change product specifications without notice.

ORDERING INFORMATION

CONSULT FACTORY

ALL DIMENSIONS: INCHES [MILLIMETERS]

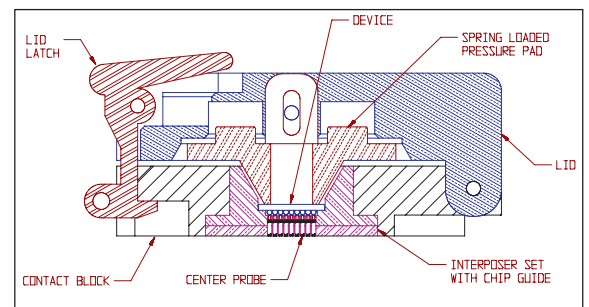
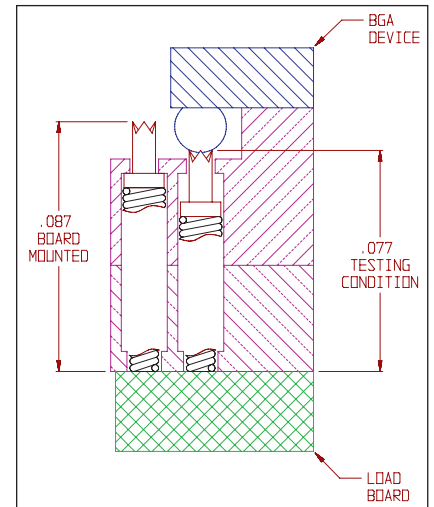
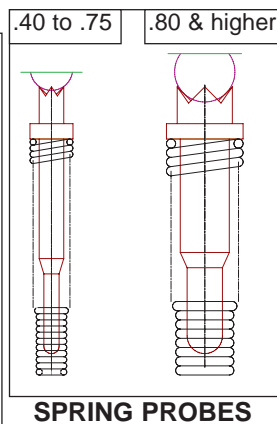
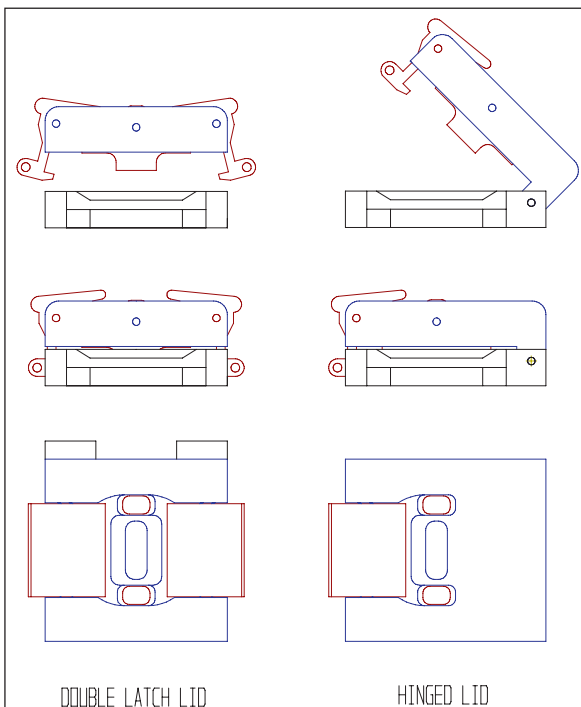

ARIES[®]
ELECTRONICS, INC.
http://www.arieselec.com • info@arieselec.com

Frenchtown, NJ USA
TEL: (908) 996-6841
FAX: (908) 996-3891



24010
REV.G